

Maximum precision and reliability

ultego® III





Contents

ultego III	4
For optimal results	4
Consistent metering on principle	5
Meter selection – installation in horizontal and vertical pipes	6
Technical data	7
Overview	8
ultego III smart	9
Compact version	9
Technical data	10
Pressure loss curves	11
Display loops	12
ultego III perfect – highest precision and reliability	14
Technical data	15
ultego III – accessories	16
Immersion sleeves and welded sleeves	16
Ball valves	17
Installation of temperature sensor	18
Legal calibration conditions	19
Installation examples	20
Installation instructions	22

For optimal results

Functional description

With its different model ranges, the heat meter generation ultego III offers a variety of options for combination and application. The ultego III smart compact version combines the calculator, flow sensor and temperature sensor pair into one device and offers almost unlimited applications. With two external sensors, the heat meter fulfils all requirements of the new European Measuring Instrument Directive.

All flow sensors in the ultego model ranges work with the wear-free ultrasound metering principle with no mechanical moving parts.

Two ultrasonic transducers alternately transmit ultrasound waves in and against the direction of flow. The time difference is used to calculate the flow speed, which is used to determine the flow rate and volume. Volume proportional pulses carry this information to the calculator.

Performance features

The ultego III smart compact devices are available for nominal flow rates of 0.6/1.5/2.5 m³/h.

For the calculators of the combined heat meters, flow sensors with nominal flow ratings of 0.6 to 30 m³/h and temperature sensors with lengths of 3 m and 10 m are available.

Power is supplied by a lithium battery. The service life of the battery is ten years plus one year reserve.

Area of application

- Heating systems with water as a heat transfer medium
- Recording energy with central hot water supply systems
- Energy recording in central domestic systems
- Local and district heating transmission stations
- Larger heating systems in multiple dwellings
- Nominal flow rate of 0.6 to 60 m³/h

ultego III

With their compact design, the ultego III smart heat meters are ideally designed for metering in apartments whereas the ultego III perfect is designed for flow rates up to 60m³/h. We also can offer combined heat meters for bigger flow rates. All ultego heat meters can be integrated into the symphonic 3 radio system in conjunction with the optosonic u 3 radio net.

Interfaces

In addition to above mentioned radio module, the ultego III heat meters can be supplied with pulse and M-bus modules for integration with building management systems.

Accurate metering via ultrasound technology

The ultrasound metering principle of the ultego III, which has proven itself over many years, guarantees precise metering of heat volumes, which is stable over a long period. Impurities in the water generally have no influence on the metering precision.



Your benefits

- Precise, reliable and wear-free metering
- Stable behaviour over the long term
- Defined overload behaviour
- Precise recording of even the smallest flow volumes
- Dirt-resistant and consistent metering thanks to the lack of moving parts
- Extraordinarily low energy consumption
- Low pressure loss
- Fast, intelligent temperature measurement grid
- Horizontal or vertical installation according to preference (ultego III smart also overhead and with removable calculator)
- Measuring range, flow rate 1 : 100 acc. to EN 14341, overall : 1000
- Security against manipulation via sealing

Consistent metering on principle

The ultego III is characterised with a long service life, metering stability and a highly dynamic range. The design of the sensors makes the flow sensors of the meter resistant to pressure surges. Even after several years of use in heating systems, the ultrasound heat meters record the volumetric flow precisely and reliably. The stable long-term behaviour and high metering precision are just further reasons why the ultego III meets the highest demands.

Broad product range

The principal area of application of the ultego III is heating systems with water as a heat transfer medium. It is not suitable for systems with water/glycol mixtures. The device is characterised by its high flexibility in terms of metering. It is available both for different flow ratings as well as in different lengths.

Using the selection tables on the next pages, you can easily find the right heat meter for your system.



ultego III meter selection – installation in horizontal and vertical pipes

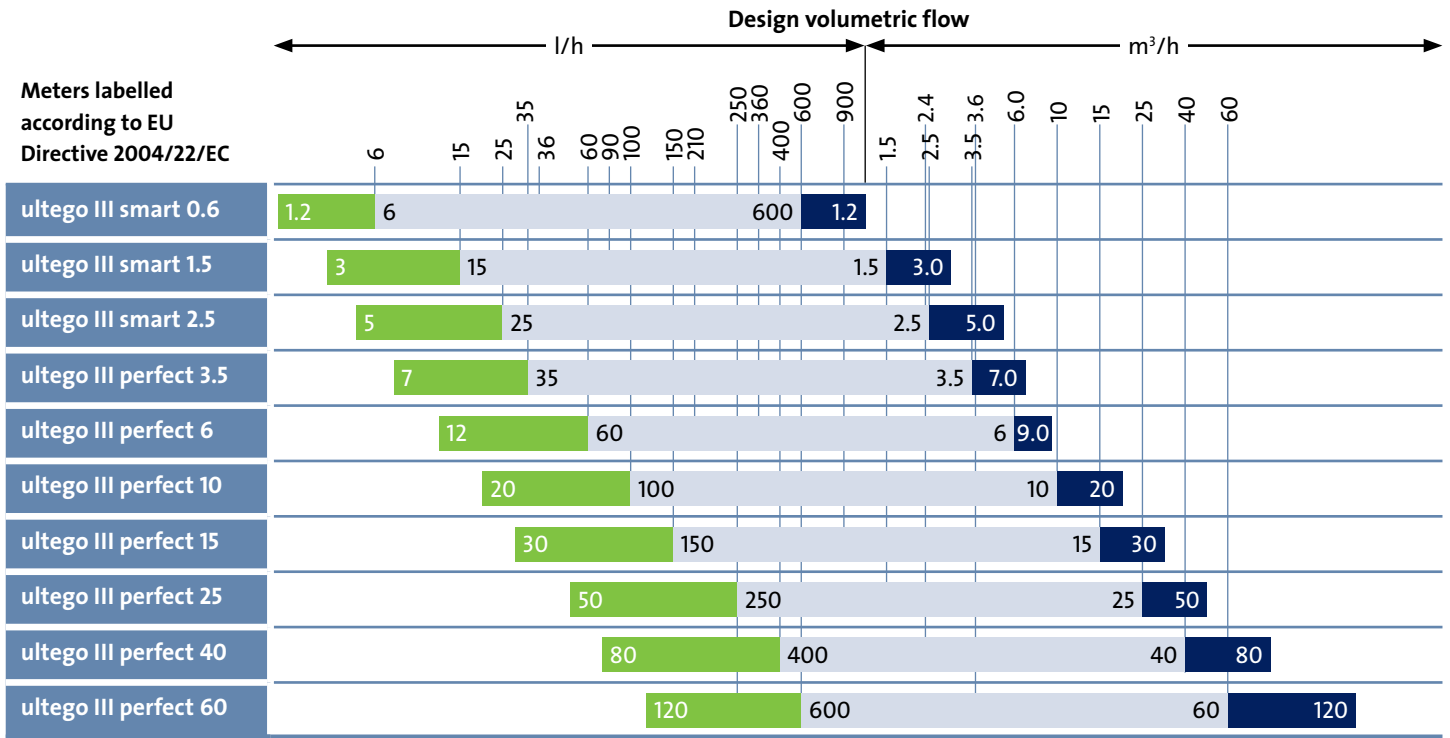

Measurement range in accordance with EU Directive 2004/22/EC

Start-up range
 Entire measurement range
 Maximum flow rate
 Minimum flow rate = q_i
 Nominal flow rate = q_p
 Maximum flow rate = q_s

Technical data

Description, see page	Measuring method	Model range	Flow sensors							Microprocessor calculator				
			Nominal flow rate q_p in m^3/h	Pressure loss p	Connection		Nominal width DN in mm	Maximum water temperature in °C	Nominal pressure PN 16	Display unit	Temperature range Theta (Θ) in °C	Temperature Delta difference Delta Theta ($\Delta\Theta$) in K		
					Thread in accordance with ISO 228/1	Flange in accordance with DIN 2501								
9	Ultrasound	ultego III smart	0.6	75	●		15	5-90	16	0.01 MWh	0-180	3-80		
			1.5	135	●		20		16					
			2.5	165	●		25		16					
14	Ultrasound	ultego III perfect	3.5	65	●	●	25	10-130 Up to 150 for 2,000 h	25	0.1 kWh	5-150	3-100		
			6	152	●	●	25		25					
			10	120	●	●	40		25					
14			15	120		●	50		25	0.001 MWh				
			25	70		●	65		25					
			40	120		●	80		25					
			60	140		●	100	25						

How to determine the right heat meter

The design volumetric flow is decisive in selecting a heat meter. The highest possible volumetric flow must be equal to or smaller than the permissible nominal flow rate Q_n/q_p . The lowest volumetric flow must be greater than the minimum flow rate Q_{min}/q_i .

In certain cases, regulating devices, such as allocators, butterfly valves, mixing valves or overflow valves must be adapted.

This is how to use the selection table on page 6

Follow the table from your calculated outflow volume vertically downwards until you reach

the light blue bar of a heat meter. This is the right heat meter for your purposes.

If you encounter several light blue bars, i.e. if several heat meters are suitable, please make a decision using the criteria of model type, pressure loss and lowest occurring volumetric flow.

ultego III – overview

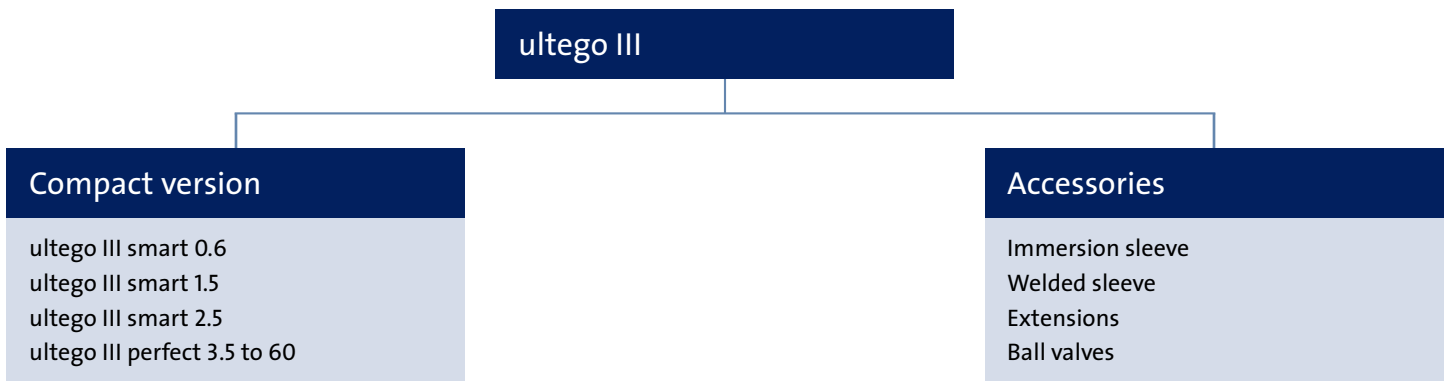

The ultego III ultrasound heat meter product range includes compact versions, combined heat meters and extensive accessories.

Two model ranges with various combination variants offer you a variety of applications in

heat metering. The wear-free ultrasound metering principle with no mechanical moving parts guarantees precise volume recording and metering in all meters.

The ultego III smart and perfect compact heat meters have large, clearly arranged LC

displays presenting a range of values (e.g. energy volume, volumes, effective date figures, month-end figures).

The ultego III heat meters can also be integrated into the symphonic 3 radio system.

ultego III smart – compact version

The ultego III smart is a compact heat meter for physically accurate recording of energy consumption. The device comprises a flow sensor, two fixed connected temperature sensors and a calculator that calculates energy consumption using the volume and temperature difference.

The meter is very easy to install and read. With its outstanding properties, such as high metering precision, freedom from maintenance and long service life, the ultego III smart contributes to minimising annual operating costs.

Volume recording works in accordance with the wear-free ultrasound metering principle with no mechanical moving parts.

The water volume is measured in the meter pipe via ultrasonic pulses emitted in and against the direction of flow. The time between transmitter and receiver is reduced downstream and extended upstream accordingly. The water volume is then calculated from the metered values of these times.

The forward flow and return flow temperature is determined using platinum resistors.



The ultego III smart records the flow rate in a 4-sec and the temperature in a 4/60-sec measurement grid.

Intelligent, adaptive temperature measurement grid

In changing system conditions (e.g. surge in flow rate >30 %), the ultego III smart switches for a certain amount of time to a fast

temperature measurement grid of 4 sec. As soon as the temperature difference changes by less than 1 K, or after 2 min at the latest, the longer measurement grid is resumed.

Thus, the meter always adapts to the current situation with “ultra-precise” recording of the system temperatures.

ultego III smart – technical data

Devices with 2 external sensors Meters labelled according to EU Directive 2004/22/EC (symmetrical sensor installation)		ultego III smart 0.6	ultego III smart 1.5	ultego III smart 2.5
Forward flow sensor length	m	1.5	1.5	1.5
Return flow sensor length	m	1.5	1.5	1.5
Part No.		77630	77631	77632
Flow sensor				
Maximum flow rate q_s	m ³ /h	1.2	3.0	5.0
Pressure loss Δp at q_p	mbar	75	135	165
Minimum flow rate q_i	l/h	6	15	25
Response limit	l/h	1.2	3	5
Nominal pressure PN	bar		16	
Temperature range limit values	Θ		5–90	
Installation position			As required	
Protection class			IP65	
Permissible metering error			Acc. to EN 1434 (class 2/3)	
Inflow and outflow sections			Not required	
Microprocessor calculator				
Temperature range limit values	Θ		0–180	
Temperature difference limit values	ΔΘ		3–80	
Temperature difference suppression			< 0.2	
Flow rate measurement grid	sec.		4	
Temperature measurement grid, adaptive	sec. sec.		60 Standard 4 with surge in flow rate, > 30 %	
Heat coefficient K			Variably compensated rt	
Ambient temperature	°C		5–55	
Ambient conditions			Acc. to DIN EN 1434	
Display of heat consumption			7-digit including one decimal place	
Power supply			Integrated 6-year battery*	
Protection class			IP54 acc. to EN 60529	

* For Switzerland and Luxembourg, other battery lives and conditions apply.

ultego III smart – Pressure loss curves

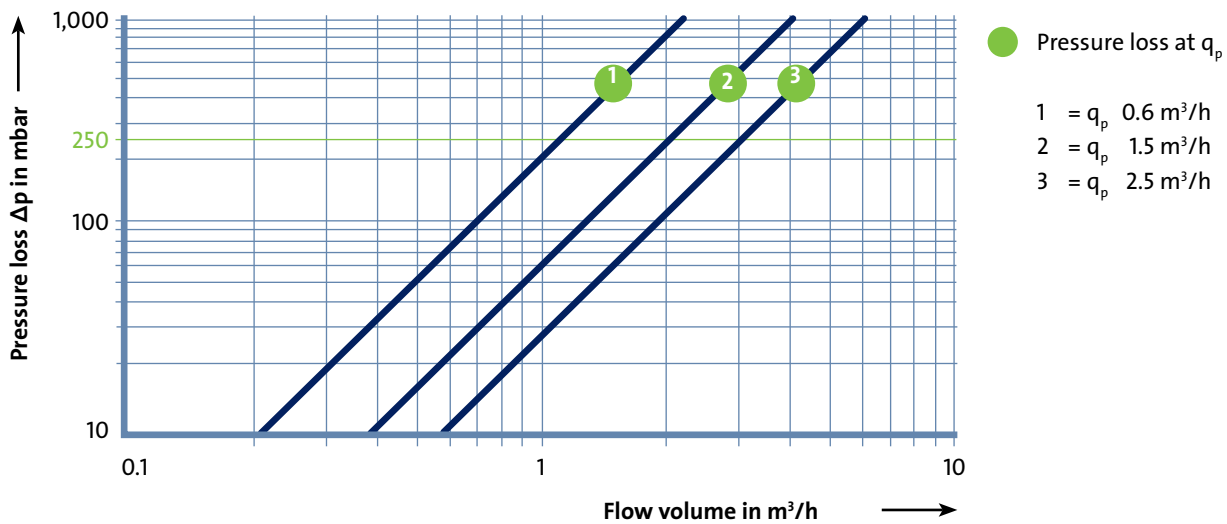

ultego III smart

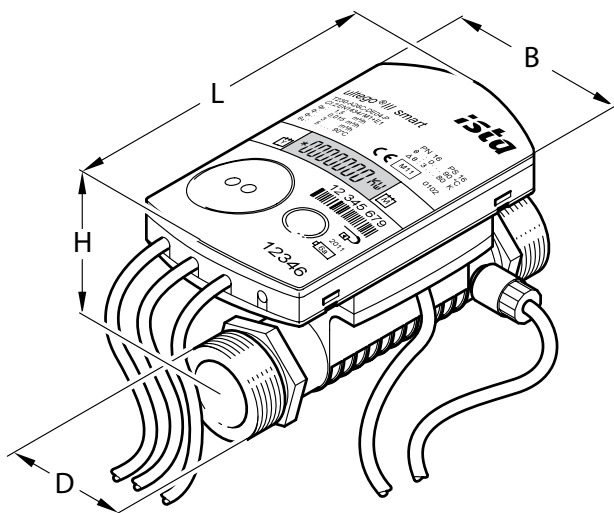

Devices with 2 external sensors	ultego III smart 0.6	ultego III smart 1.5	ultego III smart 2.5	
Nominal flow rate q_p	m ³ /h	0.6	1.5	2.5
Max. depth T	mm	70	70	70
Pipe connection D	G 3/4	G 3/4	G 1	
Height H	mm	57.7	57.7	60.3
Length L	mm	110	110	130

ultego III smart – display loops

The ultego III smart has a large, clearly arranged LC display with seven digits for displaying various values (e.g. energy volume or volumes). The innovative activity display enables detection of a positive flow at a glance of the display. Simple symbols for previous year's and previous month's value enhance the clear and simple display concept.

The meter displays are arranged in several display loops and may differ from the standard version shown here. Pressing the key briefly (< 2 sec) cycles through the current loops line by line. After the last line, the first line is shown again. Holding down the button (> 3 sec) calls up the first line of the next loop up. After the last loop, the first is shown again.

The arrow symbols that point to the previous year's or previous month's figure indicate the display of a saved previous year's or previous month's figure. A calibrated value (e.g. energy volume) is indicated by the display of a star symbol. The decimal places of displayed figures are marked with a border.

User loop (Loop 0)

LOOP 0

*1234567^{hr}

Energy volume

*1234567^{hr}

Volume

*00000000^{hr}

Segment test

F:---

In the event of an error, error message with error code

Instantaneous values (Loop 1)

LOOP 1

1234^{hr}

Current flow rate

904^{hr}

Current heat output

910 °C

560 °C

Current forward flow and return flow temp. in 2-sec cycle

bd 1234 h

Operating time with flow rate

Fd 123 h

Downtime

Pd 1234 h

Time with flow rate

Last month's figures (Loop 2)

LOOP 2

010110st

Save date

123456.7^{Wh}

123456.7^{Wh}

Energy volume and volumes on effective date

Fd 123 h

Downtime on effective date

3899^{Wh}

0904.10st

Max. flow rate on effective date in 2-sec cycle with date stamp

2889^{Wh}

0904.10st

Max. performance in 2-sec cycle with date stamp

980 °C

0904.10st

Max. forward flow temp. in 2-sec cycle with date stamp

870 °C

0904.10st

Max. return flow temp. in 2-sec cycle with date stamp

General/communication (Loop 3)

LOOP 3

1234567^G

Device number, 7-digit

M-bus

Optional interface

127^A

Primary address (only with M-bus)

0000000^A

Secondary, 7-digit (only with M-bus)

3105--

Year effective date

31--

Month effective date

15-00^{RA}

Firmware version

C-C,1234

CRC-code of part subject to calibration

Other (Loop 4)

LOOP 4

010110st

Datum

105959^T

Time

---- C

Code input for inspection/para mode

ultego III perfect – highest precision and reliability



Reliable Measurement

Longevity, measuring stability and a high dynamic range distinguish the ultego III perfect. Even after operating for years in the

district heating water environment with low conductivity the ultego III perfect is measuring the volume precisely and reliably. Due to the patented DuraSurface, we are

setting new standards in measurement stability. This future-oriented innovation ensures measuring accuracy and maintenance-free operation for many years.

Technical data

Nominal flow Q_n/Q_p	m^3/h	3.5	6	10	15	25	40	60
Meteorological Class		1:100	1:100	1:100	1:100	1:100	1:100	1:100
Maximum flow rate Q_s	m^3/h	7.0	12	20	30	50	80	120
Minimum flow rate Q_i	l/h	35	60	100	150	250	400	600
Response limit	l/h	14	24	40	60	100	160	240
Pressure loss Δp at Q_p								
Thread	mbar	65	150	100	–	–	–	–
Flange	mbar	65	150	165	100	105	160	115
Pressure loss $\Delta p = 1$ bar								
Thread	$K_v m^3/h$	14	15	32	–	–	–	–
Flange	$K_v m^3/h$	14	15	32	48	77	100	177
Installation position		Variable						
Temperature range limit values		5...130 °C						
Maximum temperature	t_{max}	150 °C for 2000h						
Nominal pressure	PN	1.6 MPa (PN16)			2.5 MPa (PN25)			1.6 MPa (PN16)
		2.5 MPa (PN25)			2.5 MPa (PN25)			2.5 MPa (PN25)
Permissible metering error acc. EN 1434 (Class 2)		2 + 0.02 q_p/q % max. 5%						

ultego III – accessories ball valves immersion sleeves and welded sleeves

The ista immersion sleeves for holding the temperature sensors can be mounted with pinpoint accuracy. The immersion sleeves can be supplied individually or as a set with a welded sleeve.

Immersion sleeve set 5, mm*

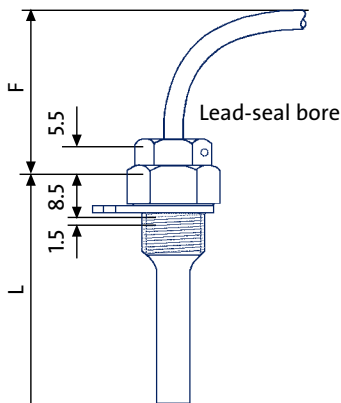
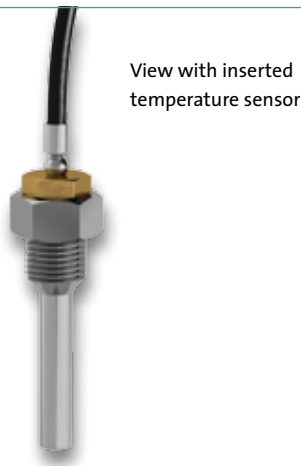

Length L 1	Free space F 1	Part No. H
50 mm	70 mm	18380
80 mm	100 mm	18381
150 mm	170 mm	18382

Immersion sleeve set, 5 mm, with welded sleeve*



Text

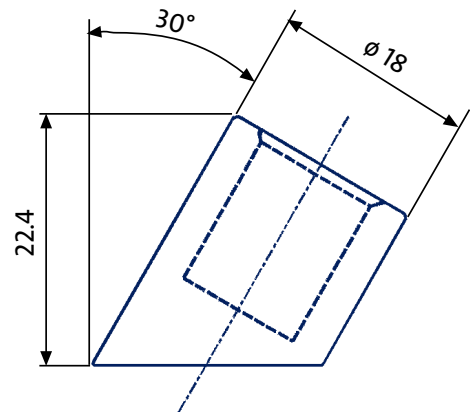

Nominal pipe width 1	Immersion sleeve length 1	Part No. 1
32–40 mm	50 mm	18391
50–120 mm	80 mm	18392
150–300 mm	150 mm	18393

* All dimensions in mm.

Ball valves

The temperature sensors can be installed directly in conjunction with the corresponding ball valves. For the new installation of heat meters, in accordance with the Calibration Order, installation of temperature sensors is only permissible directly in pipes up to DN 25. If corresponding ball valves are installed in the forward flow and return flow pipe of the heating system, the meter can be exchanged regularly without a problem.

Performance features

- Ball valves for hot water heating systems with sensor connection M 10 x 1
- Metal butterfly handle with stop, hard chrome-plated ball with Teflon seal and spindle with double O-ring seal
- Housing in nickel-plated brass, internal thread on both sides

Ball valve with screw-in connector for temperature sensor

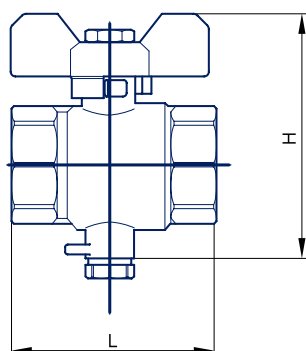

Connection 1	Length L I	Height H I	Part No.
RP 1/2	51.8 mm	75.9 mm	18529
RP 3/4	57.5 mm	76.1 mm	18527
RP 1	67.0 mm	91.6 mm	18528

Installation of temperature sensor

Installation of temperature sensor directly via ball valve

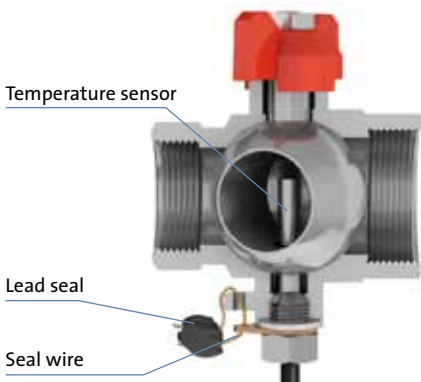

The correct installation of the temperature sensor in the forward flow and return flow pipe of the heating system is of critical importance for the metering system. With new installation of heat meters in pipes smaller than or equal to DN 25, in accordance with the Calibration Order, the temperature sensor must be installed with direct immersion. With larger pipes, installation in conjunction with immersion sleeves is permissible. Here, it is important to select the right immersion sleeve, which is independent of the nominal pipe width. The pipe walls and installation locations are to be fitted with thermal insulation in order to minimise the temperature gradient between the measuring resistors and installation locations.

Installation of temperature sensor via immersion sleeve in straight pipe section

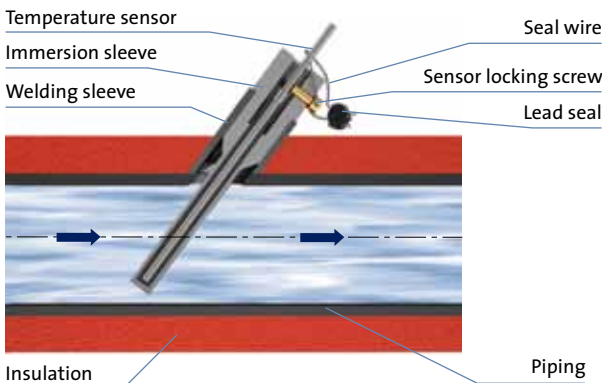

The temperature sensors flow in the direction of the arrow. The correct immersion depth of the temperature sensors can be precisely determined using the immersion sleeve set selection table.

Advice on measures in existing heating systems

The future-oriented installation of heat meters and their temperature sensors – in pipes smaller than or equal to DN 25 – is only guaranteed in conjunction with the installation of ball valves. If work on the heating system is required – e.g. replacing the boiler, modernisation, renovation etc. – ball valves should also be installed at the same time (for mounting the temperature sensors) in the forward flow and return flow pipes of the system. Advantage: The expenditure is manageable and it is ensured that the installation locations will continue to fulfill all legal requirements in the future.

Installation of temperature sensor via immersion sleeve in pipe bends of 90°

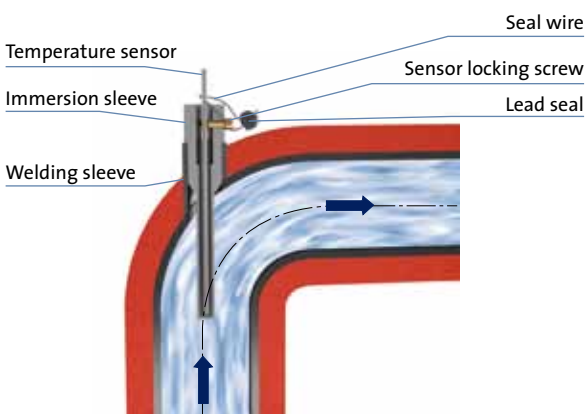

Legal calibration conditions

European and German law*

As part of new European calibration regulations on 30 October 2006 and the specifications of the European Measuring Instruments Directive (MID), 2004/22/EC, there are new requirements, which include those relating to the installation of heat meters. The requirements were enshrined in national law with the fourth order for the amendment of the Calibration Order and are thus binding for new installations. Requirements for accurate and consistent recording with heat meters include the precise determination of the temperature difference between the forward flow and return flow of the heating system. The type and method of installation of the temperature sensor is of decisive importance.

The legislators therefore prescribe as follows in the Calibration Order: With new installations (of heat meters) in pipes smaller than or equal to DN 25, short temperature sensors must only be installed with direct immersion. The installation of temperature sensors in immersion sleeves is no longer permissible in this case. In practice, this means: During heating, the heating medium must flush directly around the temperature sensor. This is ensured by installing ball valves in the forward and return flow pipe of the heating system. The installation of sensors in conjunction with two ball valves is also the ideal solution for replacement in the context of the validity period of five years. Since 30 October 2006, new approvals of heat meters can only be carried out in accordance with the specifications of the MID.

Transitional regulation for existing systems

A requirement for the calibration of heat meters was the national type approval via the Physikalisch-Technische Bundesanstalt (PTB). The current applicable legal requirements at the time of approval of the meter are authoritative for the use of heat meters. Heat meters that conform to the Directives applicable to 12 February 2007 may only be installed up to the expiry of the type approval, or by 30 October 2016 at the latest. The transitional regulation ensures that the replacement of heat meters with appropriate meters within calibration periods is also secured. National approval symbol for a meter



Heat meters for all requirements

ista supplies the right heat meter for all applications.

New installation of heat meters

For new/initial installations of heat meters, the compact version is available with two external sensors. In this version, the temperature sensors are installed in conjunction with two ball valves. The symmetrical installation of the sensors fulfils the requirements of the European Measuring Instrument Directive (MID). The heat meters are labelled with the CE mark.

CE CE = Conformité Européenne
= “Conformity with EU Directives”

Example of a CE-mark:

CE M10 0102

M = Metrology label
10 = curr. year of conformity
0102 = four-digit identifier for the designated authority, here the PTB

Replacement of heat meters

Previously, heat meters in the compact version were primarily installed with a return flow sensor integrated in the flow sensor. In addition, in many cases, temperature sensors were installed via immersion sleeves and not directly in conjunction with ball valves. A compact version of our heat meters remains available for this application. The national approval by the PTB is labelled via the national approval symbol.



22.12 = Approval for a compact heat meter;
22 = Heat meter,
12 = Complete heat meter
99.02 = Year and consecutive number of the approval from the PTB

Calibration obligation for heat meters

Regardless of the approval of a heat meter, in accordance with the MID or PTB, the period of validity of the initial calibration or CE mark is five years. After this, replacement of the heat meter is necessary.

* For Switzerland and Luxembourg, other battery lives and conditions apply.

Installation examples

Control group

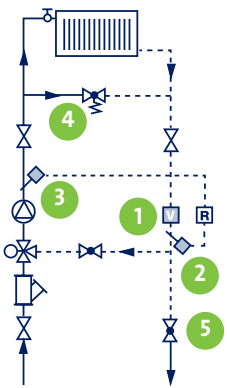

Example of a complete control group

- 1 Flow sensor of the heat meter in the return, the colder section. Shut-off devices must always be present.
- 2 Return flow temperature sensor in the area of a good water mix, immediately downstream of the water meter.
- 3 Forward flow temperature sensor in the area of a good water mix, behind the circulation pump.
- 4 Overflow device to guarantee a flow greater than Q_{\min} / q_i .
- 5 Butterfly valve or balancing valve in constant volumetric flow for setting the required temperature spread.

Heating group

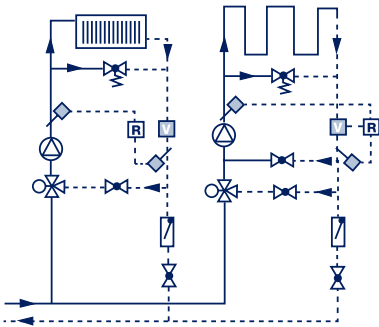

Example of two heating groups with radiators and underfloor heating

Installation of heat meters in the consumption circuit, in which the circulation pump ensures constant water volume. The butterfly valve can be omitted if there is a maximum limitation of the forward flow in the controls.

The operating conditions of the two consumption circuits are different. When selecting the heat meter, ensure that the volumetric flow is low for radiator heating and high for underfloor heating.

Radiator

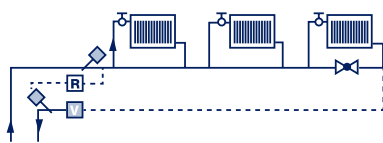

Example of individual radiators of a user

Heat consumption metering of the individual radiators of a user within a domestic unit. The individual radiators are connected to a ring main.

Heating plant

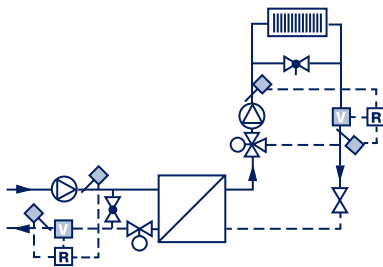













Example of a heating system with heat exchanger

On the one hand is the possibility of metering upstream of the heat exchanger. In this case, the losses of the heat exchanger are taken into account and higher pressures and

temperatures occur. On the other hand, installation of the heat meter in the consumption circuit allows metering downstream of the heat exchanger. An almost constant volumetric flow is often opposed with only small temperature differences.

Explanation of symbols

- | | | |
|---|--|--|
|  Flow sensor |  Three-way valve |  Non-return valve |
|  Calculator |  Globe control valve |  Dirt trap |
|  Return temperature sensor |  Pressure relief valve |  Radiator heating |
|  Supply line temperature sensor |  Butterfly valve with fixed setting | |
|  Recirculation pump |  Shut-off valve | |

Installation instructions

Heat meters are precision-electronic meters that must be handled properly. When installing the devices, please observe the enclosed installation instructions. In principle, heat meters should only be installed in a circuit (primary or secondary).



Flow sensors

Flow sensors are, in principle, installed in the return flow pipe, the colder section. Shut-off valves must be installed upstream of and behind the installation location to enable easy replacement of the meter.

Temperature sensor

Temperature sensors in the forward flow and return flow must be installed in the same circuit as the flow sensor and against the direction of flow. Forward flow sensors are marked red and return flow sensors blue. The sensor cables must not be shortened or extended. ista temperature sensors have a sensor connection of M 10 x 1, which enables direct installation in ball valves. When temperature sensors are used in conjunction

with immersion sleeves, the sensors must be inserted into the immersion sleeves down to the stop and fixed in place. The installation location of the temperature sensor should be insulated.

Compact heat meters and part components of combined heat meters, such as calculators, flow sensors and temperature sensors, should always be sealed.

ista Energy Solutions Ltd

3 Riverside ■ Granta Park ■ Great Abington
Telephone +44 (0) 1223 874974
info@ista-uk.com ■ www.ista-uk.com

ista International GmbH

Grugaplatz 2 ■ 45131 Essen ■ Germany
Telefon +49 (0) 201 459-02
info@ista.com ■ www.ista.com